

## Area and Perimeter of Compound Shapes (A)

Instructions: Find the area and perimeter of each compound shape.

1)

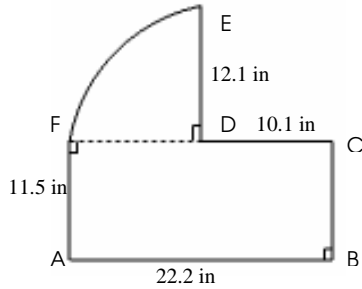

2)

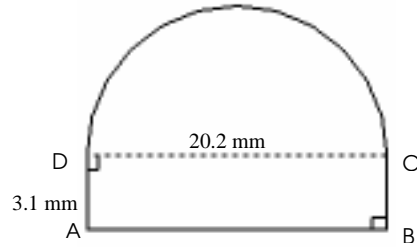

3)

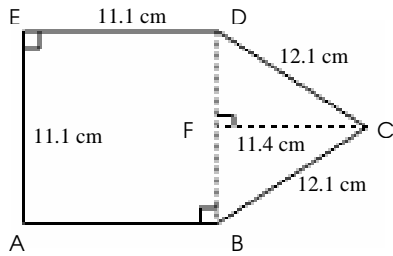

4)

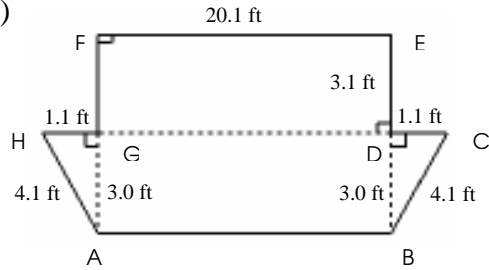

5)

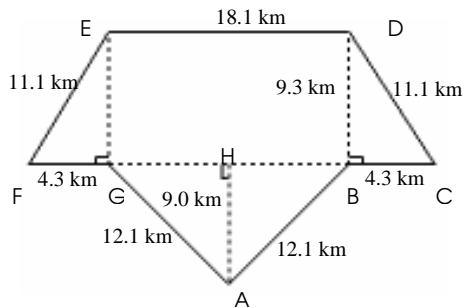

6)

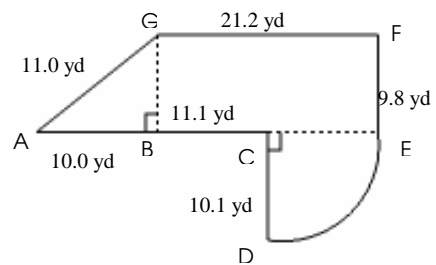

# Area and Perimeter of Compound Shapes Answer (A)

Instructions: Find the area and perimeter of each compound shape.

1)

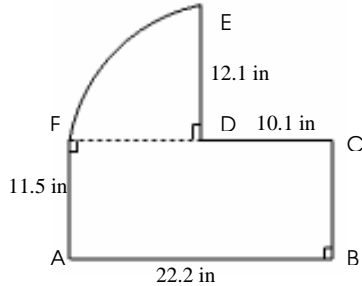

Area = Area of ABCF + Area of Part Circle DEF  
 $= (AB \times AF) + 0.25 \Pi (DE)^2$   
 $= (22.2 \times 11.5) + 0.25 \times 3.14 (12.1)^2$   
 $= 370.2 \text{ in}^2$

Perimeter =  $AB + BC + CD + DE + \text{Arc } EF + AF$   
 $= 22.2 + 11.5 + 10.1 + 12.1 + 0.25 \times 3.14 \times 2 \times 12.1 + 11.5$   
 $= 86.4 \text{ in}$

2)

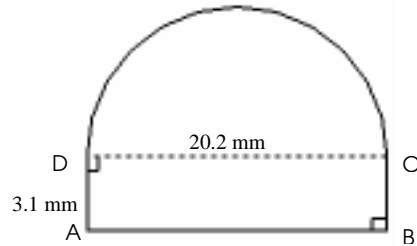

Area = Area of ABCD + Area of Part Circle DC  
 $= (AD \times AB) + 0.5 \Pi (0.5 DC)^2$   
 $= (3.1 \times 20.2) + 0.5 \times 3.14 (0.5 \times 20.2)^2$   
 $= 222.8 \text{ mm}^2$

Perimeter =  $AB + \text{Arc } BC + (2 \times AD)$   
 $= 20.2 + (0.5 \times 3.14 \times 20.2) + (2 \times 3.1)$   
 $= 58.1 \text{ mm}$

3)

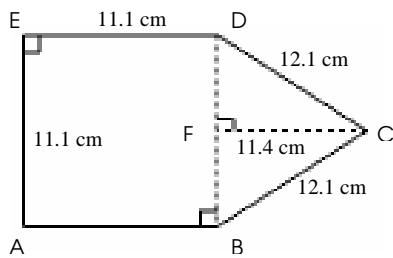

Area = Area of ABDE + Area of BDC  
 $= (ED)^2 + (0.5 \times BD \times FC)$   
 $= (11.1)^2 + (0.5 \times 11.1 \times 11.4)$   
 $= 186.5 \text{ cm}^2$

Perimeter =  $(3 \times ED) + (2 \times CD)$   
 $= (3 \times 11.1) + (2 \times 12.1)$   
 $= 57.5 \text{ cm}$

4)

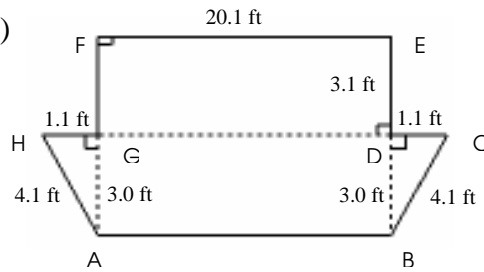

Area = Area of ABCH + Area of DEFG  
 $= (0.5 \times (AB + GD) \times BD) + (EF \times DE)$   
 $= (0.5 \times ((2 \times 20.1) + (2 \times 1.1)) \times 3.0) + (20.1 \times 3.1)$   
 $= 125.9 \text{ ft}^2$

Perimeter =  $(2 \times AH) + (2 \times EF) + (2 \times DE) + (2 \times GH)$   
 $= (2 \times 4.1) + (2 \times 20.1) + (2 \times 3.1) + (2 \times 1.1)$   
 $= 56.8 \text{ ft}$

5)

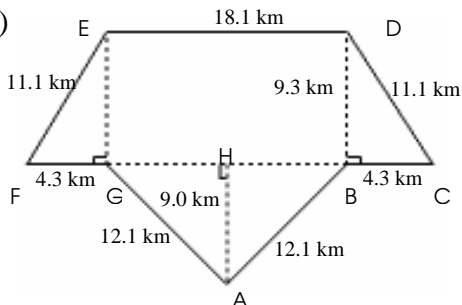

Area = Area of CDEF + Area of ABG  
 $= (0.5 \times ((2 \times BC) + (2 \times ED)) \times BD) + (0.5 \times AH \times BG)$   
 $= (0.5 \times ((2 \times 4.3) + (2 \times 18.1)) \times 9.3) + (0.5 \times 9.0 \times 18.1)$   
 $= 289.8 \text{ km}^2$

Perimeter =  $(2 \times AB) + (2 \times BC) + (2 \times CD) + ED$   
 $= (2 \times 12.1) + (2 \times 4.3) + (2 \times 11.1) + 18.1$   
 $= 73.1 \text{ km}$

6)

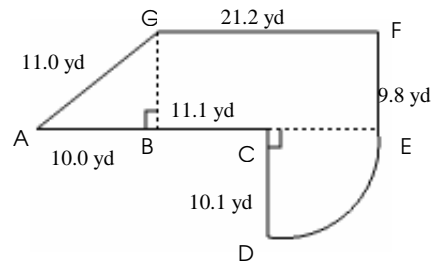

Area = Area of ACFG + Area of Part Circle CDE  
 $= (0.5 \times (AB + BC + CE + GF) \times 9.8) + 0.25 \Pi (CE)^2$   
 $= (0.5 \times (10.0 + 11.1 + 10.1 + 21.2) \times 9.8) + 0.25 \Pi (10.1)^2$   
 $= 336.8 \text{ yd}^2$

Perimeter =  $AC + CD + \text{Arc } ED + EF + FG + GA$   
 $= 21.1 + 10.1 + 0.25 \times 3.14 \times 2 \times 10.1 + 9.8 + 21.2 + 11.0$   
 $= 89.1 \text{ yd}$

## Area and Perimeter of Compound Shapes (B)

Instructions: Find the area and perimeter of each compound shape.

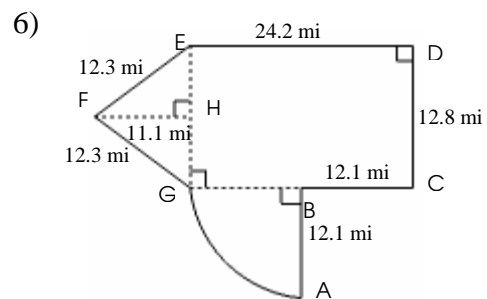
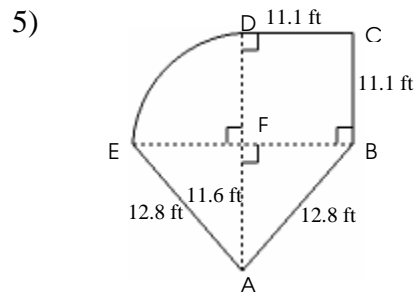
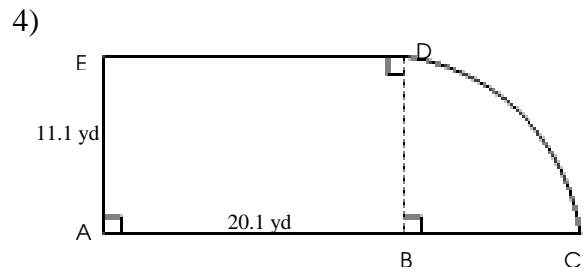
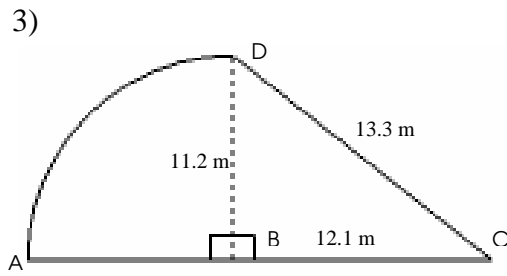
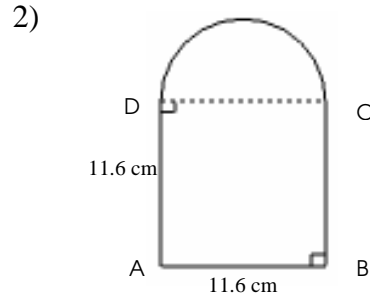
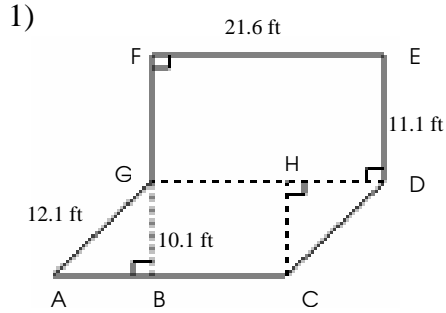

## Area and Perimeter of Compound Shapes Answer (B)

Instructions: Find the area and perimeter of each compound shape.

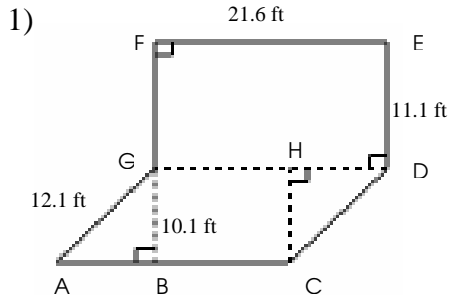

Area = Area of ACDG + Area of DEFG  
 =  $(AC \times BG) + (DE \times EF)$   
 =  $(21.6 \times 10.1) + (11.1 \times 21.6)$   
 =  $457.9 \text{ ft}^2$

Perimeter =  $(2 \times AC) + (2 \times CD) + (2 \times DE)$   
 =  $(2 \times 21.6) + (2 \times 12.1) + (2 \times 11.1)$   
 =  $89.6 \text{ ft}$

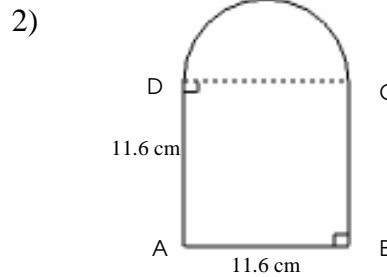

Area = Area of ABCD + Area of Part Circle CD  
 =  $(AD \times AB) + 0.5 \Pi (0.5 CD)^2$   
 =  $(11.6 \times 9.1) + 0.5 \times 3.14 (0.5 \times 9.1)^2$   
 =  $138.1 \text{ cm}^2$

Perimeter =  $AB + (2 \times AD) + \text{Arc CD}$   
 =  $9.1 + (2 \times 11.6) + 0.5 \times 3.14 \times 9.1$   
 =  $46.6 \text{ cm}$

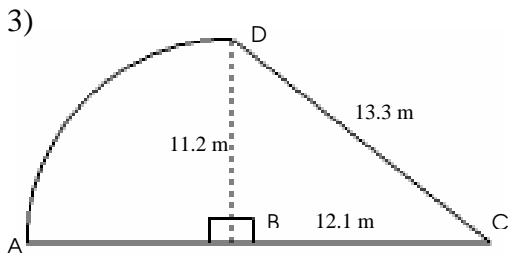

Area = Area of BCD + Area of Part Circle ABD  
 =  $(0.5 \times BC \times BD) + 0.25 \Pi (BC)^2$   
 =  $(0.5 \times 12.1 \times 11.2) + 0.25 \times 3.14 \times (11.2)^2$   
 =  $166.2 \text{ m}^2$

Perimeter = Arc AD + BC + CD  
 =  $0.25 \times 3.14 \times 2 \times 10.1 + 12.1 + 11.2$   
 =  $43.0 \text{ m}$

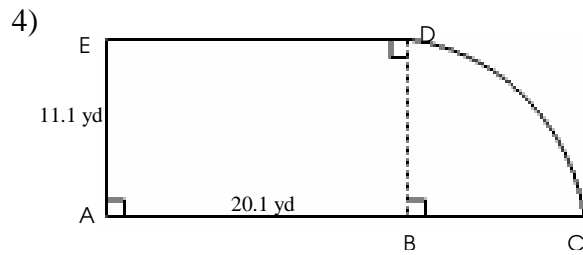

Area = Area of ABDE + Area of Part Circle BCD  
 =  $(AB \times AE) + 0.25 \Pi (BD)^2$   
 =  $(20.1 \times 11.1) + 0.25 \Pi (11.1)^2$   
 =  $319.8 \text{ yd}^2$

Perimeter =  $(2 \times AB) + \text{Arc DC} + EA$   
 =  $(2 \times 20.1) + 0.25 \times 3.14 \times 2 \times 11.1 + 11.1$   
 =  $68.7 \text{ yd}$

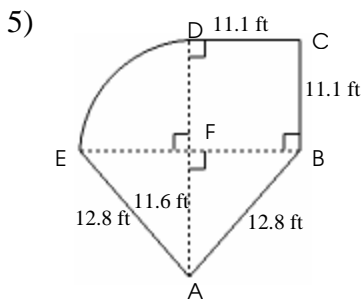

Area = Area of ABE + Area of BCDF + Area of Part Circle DEF  
 =  $(0.5 \times AF \times (2 \times BF)) + (DC)^2 + 0.25 \Pi (FD)^2$   
 =  $(0.5 \times 11.6 \times (2 \times 11.1)) + (11.1)^2 + 0.25 \Pi (11.1)^2$   
 =  $348.7 \text{ ft}^2$

Perimeter =  $(2 \times AB) + \text{Arc DE} + (2 \times CD)$   
 =  $(2 \times 12.8) + 0.25 \times 3.14 \times 2 \times 10.1 + (2 \times 11.1)$   
 =  $65.2 \text{ ft}$

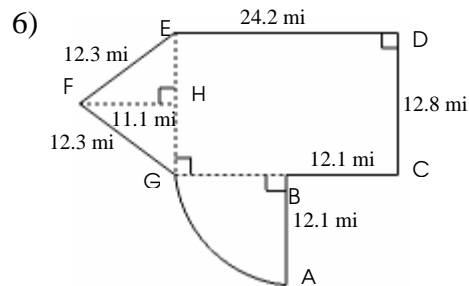

Area = Area of EFG + Area of CDEG + Area of Part Circle ABG  
 =  $(0.5 \times EG \times FH) + (CD \times DE) + 0.25 \Pi (BA)^2$   
 =  $(0.5 \times 12.8 \times 11.1) + (12.8 \times 24.2) + 0.25 \Pi (12.1)^2$   
 =  $495.7 \text{ mi}^2$

Perimeter =  $AB + BC + CD + ED + \text{Arc AG} + (2 \times EF)$   
 =  $12.1 + 12.1 + 12.8 + 24.2 + 0.25 \times 3.14 \times 2 \times 12.1 + (2 \times 12.3)$   
 =  $104.8 \text{ mi}$

## Area and Perimeter of Compound Shapes (C)

Instructions: Find the area and perimeter of each compound shape.

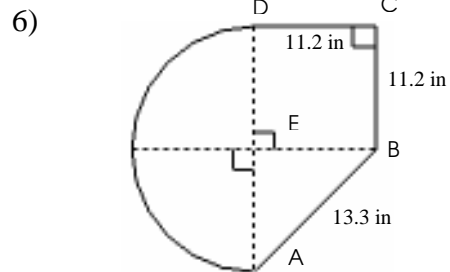
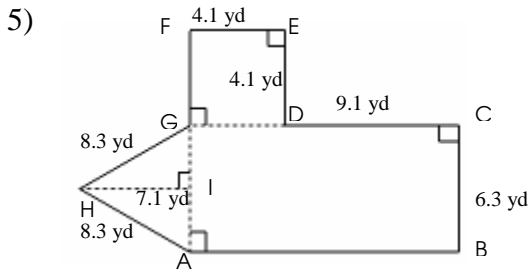
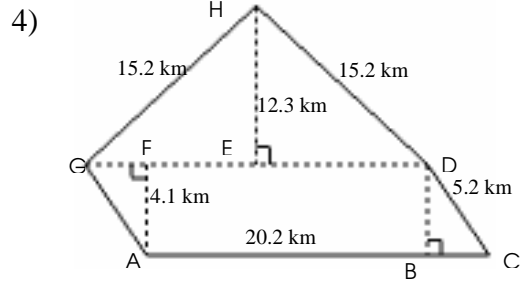
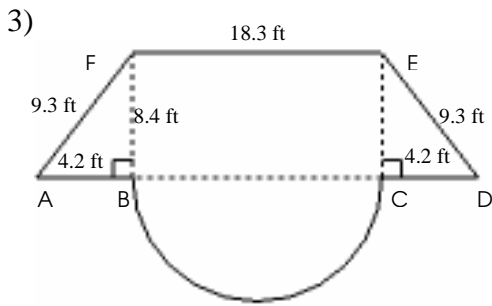
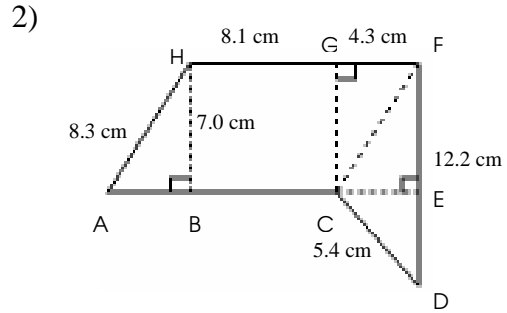
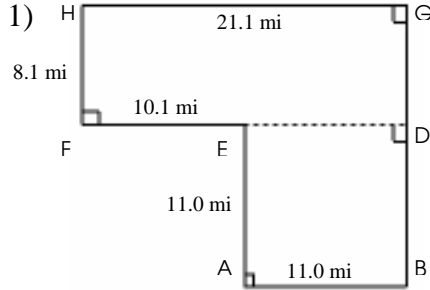

# Area and Perimeter of Compound Shapes Answer (C)

Instructions: Find the area and perimeter of each compound shape.

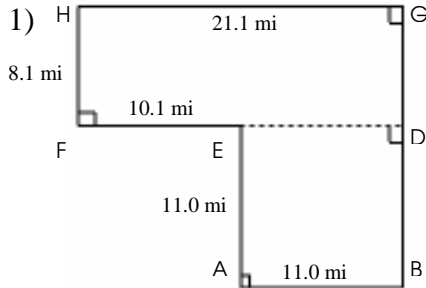

Area = Area of ABDE + Area of DFGH  
 $= (AB)^2 + (HG \times HF)$   
 $= (11.0)^2 + (21.1 \times 8.1)$   
 $= 291.9 \text{ mi}^2$

Perimeter =  $(3 \times AB) + (2 \times HF) + EF + HG$   
 $= (3 \times 11.0) + (2 \times 8.1) + 10.1 + 21.1$   
 $= 80.4 \text{ mi}$

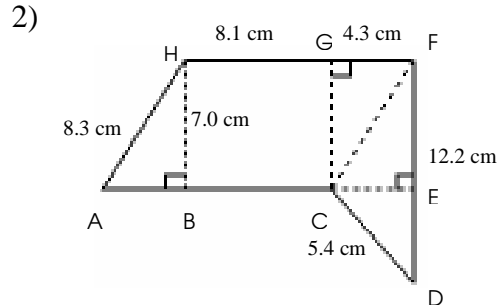

Area = Area of ACFH + Area of CDF  
 $= ((HG+GF) \times HB) + (0.5 \times CE \times DF)$   
 $= ((8.1+4.3) \times 7.0) + (0.5 \times 4.3 \times 12.2)$   
 $= 113.0 \text{ cm}^2$

Perimeter =  $(2 \times (HG+GF)) + AH + FD + CD$   
 $= (2 \times (8.1+4.3)) + 8.3 + 12.2 + 5.4$   
 $= 50.7 \text{ cm}$

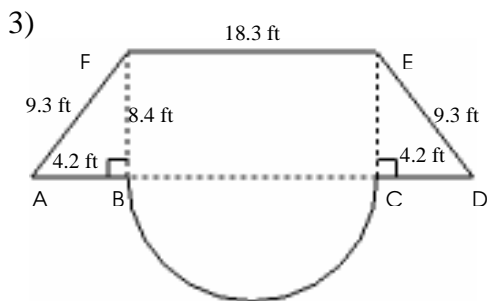

Area = Area of ADEF + Area of Part Circle BC  
 $= (0.5 \times (2 \times AB + BC + EF) \times BF) + 0.5 \Pi (0.5 BC)^2$   
 $= (0.5 \times (2 \times 4.2 + 18.3 + 18.3) \times 8.4) + 0.5 \Pi (0.5 \times 18.3)^2$   
 $= 320.4 \text{ ft}^2$

Perimeter =  $(2 \times AB) + \text{Arc BC} + (2 \times DE) + EF$   
 $= (2 \times 4.2) + 0.5 \times 3.14 \times 18.3 + (2 \times 9.3) + 18.3$   
 $= 74.0 \text{ ft}$

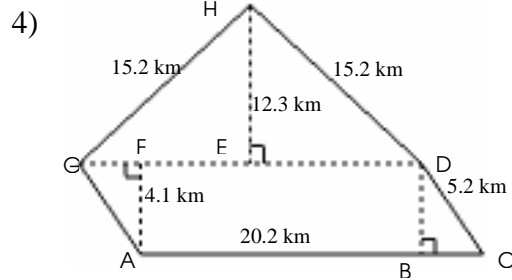

Area = Area of ACDG + Area of DGH  
 $= (AC \times AF) + (0.5 \times DG \times EH)$   
 $= (20.2 \times 4.1) + (0.5 \times 20.2 \times 12.3)$   
 $= 207.1 \text{ km}^2$

Perimeter =  $AC + (2 \times CD) + (2 \times DH)$   
 $= 20.2 + (2 \times 5.2) + (2 \times 15.2)$   
 $= 61 \text{ km}$

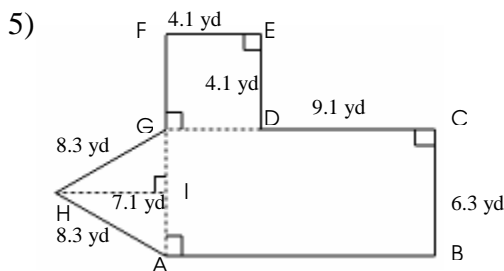

Area = Area of AGH + Area of ABCG + Area of DEFG  
 $= (0.5 \times AG \times HI) + ((CD+FE) \times BC) + (FE)^2$   
 $= (0.5 \times 6.3 \times 7.1) + ((9.1+4.1) \times 6.3) + (4.1)^2$   
 $= 122.3 \text{ yd}^2$

Perimeter =  $(2 \times AB) + BC + (2 \times FE) + (2 \times GH)$   
 $= (2 \times 13.2) + 6.3 + (2 \times 4.1) + (2 \times 8.3)$   
 $= 57.5 \text{ yd}$

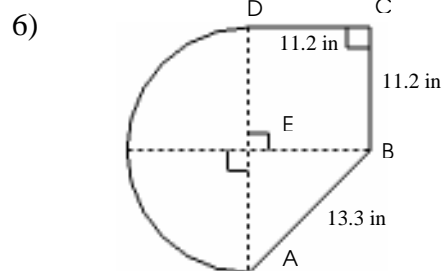

Area = Area of ABE + Area of BCDE + Area of Part Circle AED  
 $= (0.5 \times AE \times BE) + (BC)^2 + 0.5 \Pi (BC)^2$   
 $= (0.5 \times (11.2)^2) + (11.2)^2 + 0.5 \times 3.14 \times (11.2)^2$   
 $= 385.1 \text{ in}^2$

Perimeter =  $\text{Arc AD} + AB + (2 \times BC)$   
 $= 0.5 \times 3.14 \times 2 \times 11.2 + 13.3 + (2 \times 11.2)$   
 $= 70.9 \text{ in}$

## Area and Perimeter of Compound Shapes (D)

Instructions: Find the area and perimeter of each compound shape.

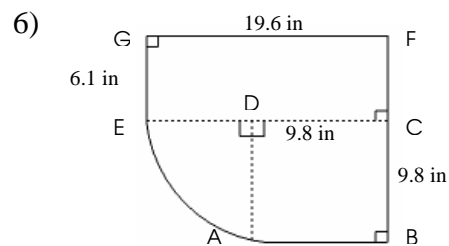
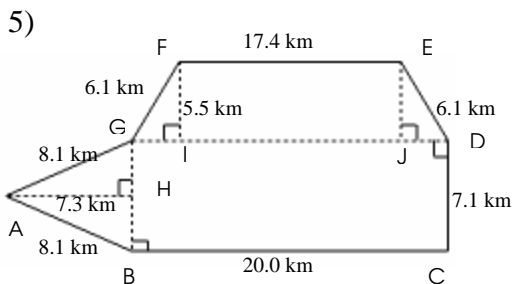
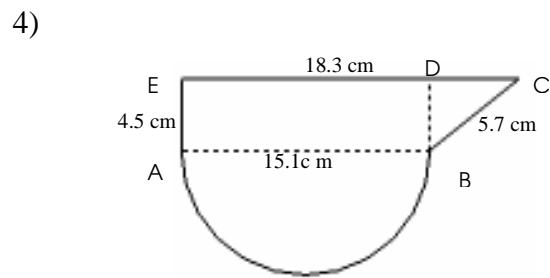
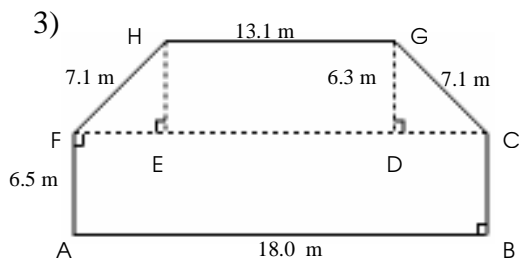
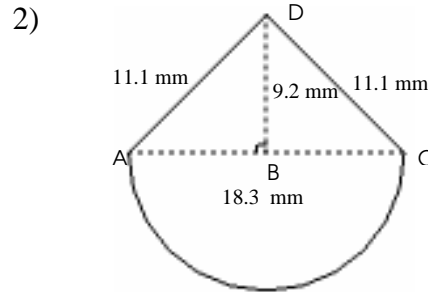
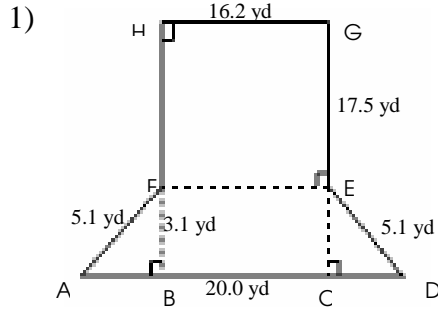

## Area and Perimeter of Compound Shapes Answer (D)

Instructions: Find the area and perimeter of each compound shape.

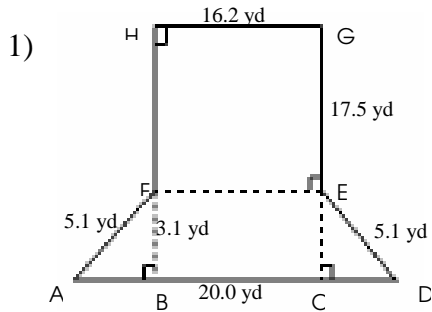

Area = Area of ADEF + Area of EFGH  
 $= (0.5 \times (AD + FE) \times BF) + (EG \times GH)$   
 $= (0.5 \times (20.0 + 16.2) \times 3.1) + (17.5 \times 16.2)$   
 $= 339.6 \text{ yd}^2$

Perimeter =  $(2 \times AF) + AD + GE + GH$   
 $= (2 \times 5.1) + 20.0 + 17.5 + 16.2$   
 $= 63.9 \text{ yd}$

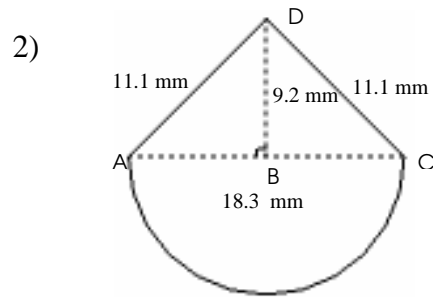

Area = Area of ACD + Area of Part Circle ABC  
 $= (0.5 \times AC \times DB) + 0.5 \Pi (0.5 AC)^2$   
 $= (0.5 \times 18.2 \times 9.2) + 0.5 \Pi (0.5 \times 18.3)^2$   
 $= 215.2 \text{ mm}^2$

Perimeter =  $(2 \times AD) + \text{Arc AC}$   
 $= (2 \times 11.1) + 0.5 \times 3.14 \times 18.3$   
 $= 50.9 \text{ mm}$

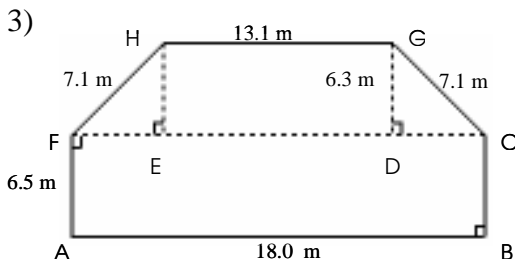

Area = Area of ABCF + Area of FCGH  
 $= (AB \times BC) + (0.5 \times (FC + HG) \times DG)$   
 $= (18.0 \times 6.5) + (0.5 \times (18.0 + 13.1) \times 6.3)$   
 $= 215.0 \text{ m}^2$

Perimeter =  $(2 \times AF) + AB + (2 \times FH) + GH$   
 $= (2 \times 6.5) + 18.0 + (2 \times 7.1) + 13.1$   
 $= 58.3 \text{ m}$

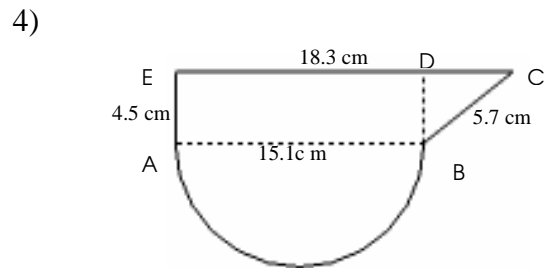

Area = Area of ABCDE + Area of Part Circle AB  
 $= (0.5(EC + AB) \times AE) + 0.5 \Pi (0.5 AB)^2$   
 $= (0.5(18.3 + 15.1) \times 4.5) + 0.5 \Pi (0.5 \times 15.1)^2$   
 $= 164.6 \text{ cm}^2$

Perimeter = Arc AB + BC + EC + EA  
 $= 0.5 \times 3.14 \times 15.1 + 5.7 + 18.3 + 4.5$   
 $= 52.2 \text{ cm}$

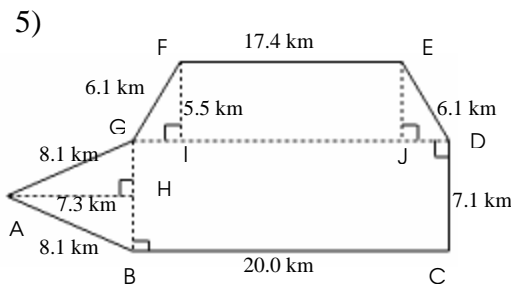

Area = Area of BCDG + Area of ABG + Area of DEFG  
 $= (BC \times CD) + (0.5 \times BC \times AH) + (0.5(GD + EF) \times IF)$   
 $= (20.0 \times 7.1) + (0.5 \times 20.0 \times 7.3) + (0.5 \times (20.0 + 17.4) \times 5.5)$   
 $= 270.8 \text{ km}^2$

Perimeter =  $(2 \times AB) + BC + CD + (2 \times ED) + FE$   
 $= (2 \times 8.1) + 20.0 + 7.1 + (2 \times 6.1) + 17.4$   
 $= 72.9 \text{ km}$

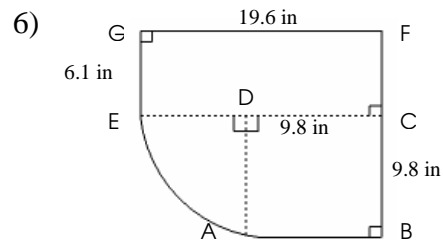

Area = Area of (ABCD + CEFG) + Area of Part Circle ADE  
 $= (BC)^2 + (FG \times GE) + 0.25 \Pi (BC)^2$   
 $= (9.8)^2 + (19.6 \times 6.1) + 0.25 \Pi (9.8)^2$   
 $= 291.0 \text{ in}^2$

Perimeter =  $(2 \times AB) + (2 \times GE) + FG + \text{Arc AE}$   
 $= (2 \times 9.8) + (2 \times 6.1) + 19.6 + 0.25 \times 3.14 \times 9.8$   
 $= 66.8 \text{ in}$

## Area and Perimeter of Compound Shapes (E)

Instructions: Find the area and perimeter of each compound shape.

1)

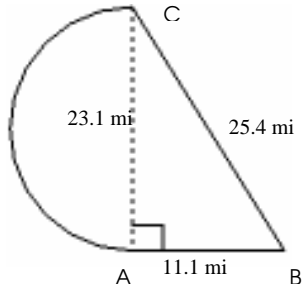

2)

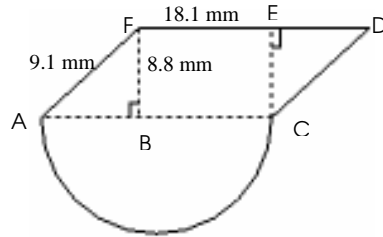

3)

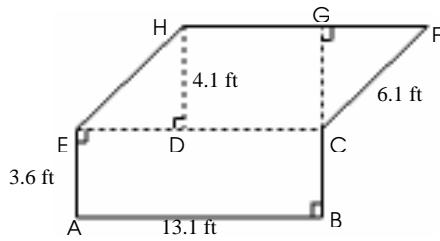

4)

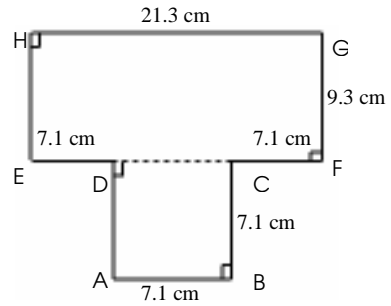

5)

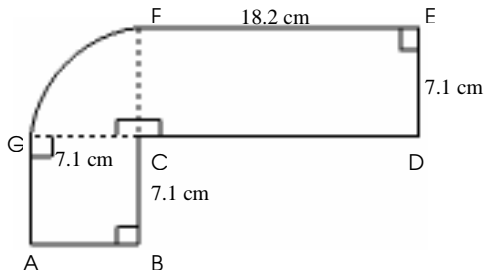

6)

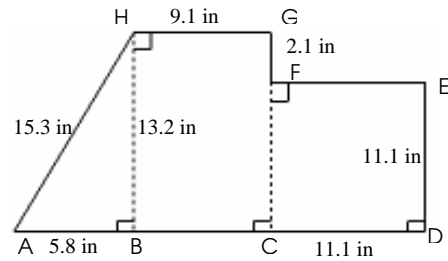

# Area and Perimeter of Compound Shapes Answer (E)

Instructions: Find the area and perimeter of each compound shape.

1)

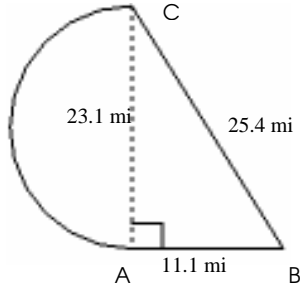

Area = Area of ABC + Area of Part Circle AC  
 $= (0.5 \times AB \times BC) + 0.5 \Pi (0.5 AC)^2$   
 $= (0.5 \times 25.4 \times 11.1) + 0.5 \times 3.14 (0.5 \times 23.1)^2$   
 $= 350.4 \text{ mi}^2$

Perimeter = AB + BC + Arc BC  
 $= 11.1 + 25.4 + 0.5 \times 3.14 \times 23.1$   
 $= 72.8 \text{ mi}$

2)

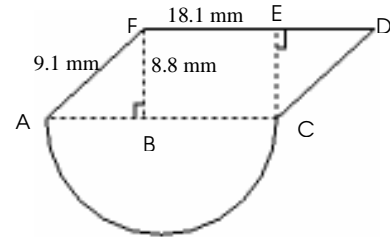

Area = Area of ACDF + Area of Part Circle ABC  
 $= (FD \times BF) + 0.5 \Pi (0.5 AC)^2$   
 $= (18.1 \times 8.8) + 0.5 \times 3.14 \times (0.5 \times 18.1)^2$   
 $= 287.9 \text{ mm}^2$

Perimeter = Arc AC + (2x CD) + FD  
 $= 0.5 \times 3.14 \times 18.1 + (2 \times 9.1) + 18.1$   
 $= 64.7 \text{ mm}$

3)

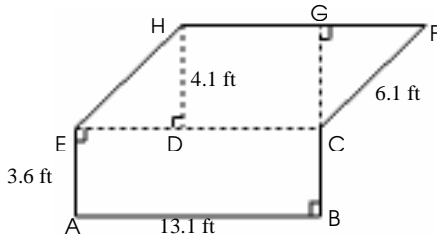

Area = Area of ABCE + Area of ECFH  
 $= (AB \times BC) + (EC \times FH)$   
 $= (13.1 \times 3.6) + (13.1 \times 4.1)$   
 $= 100.9 \text{ ft}^2$

Perimeter = (2x AB) + (2x AE) + (2x CF)  
 $= (2 \times 13.1) + (2 \times 3.6) + (2 \times 6.1)$   
 $= 45.6 \text{ ft}$

4)

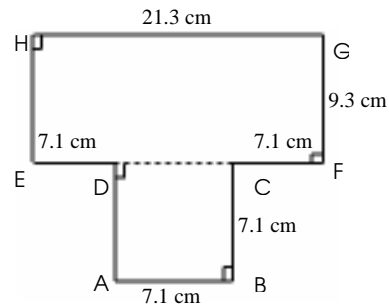

Area = Area of ABCD + Area of EFGH  
 $= (AB)^2 + (HG \times FG)$   
 $= (7.1)^2 + (21.3 \times 9.3)$   
 $= 248.5 \text{ cm}^2$

Perimeter = (5x AB) + (2x FG) + GH  
 $= (5 \times 7.1) + (2 \times 9.3) + 21.3$   
 $= 75.4 \text{ cm}$

5)

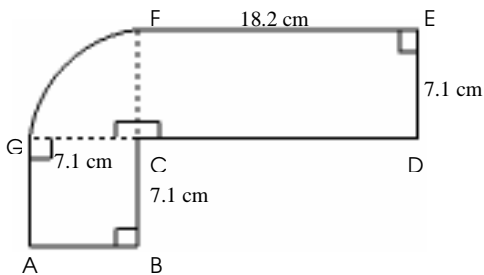

Area = Area of (ABCG + CDEF) + Area of Part Circle CFG  
 $= (BC)^2 + (FE \times DE) + 0.25 \Pi (ED)^2$   
 $= (7.1)^2 + (18.2 \times 7.1) + 0.25 \Pi (7.1)^2$   
 $= 219.2 \text{ cm}^2$

Perimeter = (4x AB) + Arc BC + (2x FE)  
 $= (4 \times 7.1) + 0.25 \times 3.14 \times 7.1 + (2 \times 18.2)$   
 $= 75.9 \text{ cm}$

6)

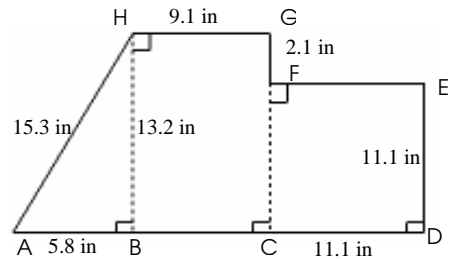

Area = Area of ABH + Area of BCGH + Area of CDEF  
 $= (0.5 \times AB \times BH) + (GH \times BH) + (ED)^2$   
 $= (0.5 \times 5.8 \times 13.2) + (9.1 \times 13.2) + (11.1)^2$   
 $= 281.6 \text{ in}^2$

Perimeter = AB + (2x GH) + (3x DE) + GF + AH  
 $= 5.8 + (2 \times 9.1) + (3 \times 11.1) + 2.1$   
 $= 74.7 \text{ in}$

## Area and Perimeter of Compound Shapes (F)

Instructions: Find the area and perimeter of each compound shape.

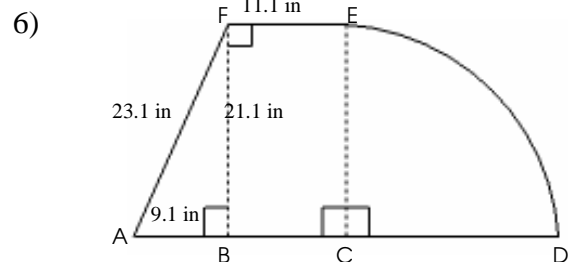
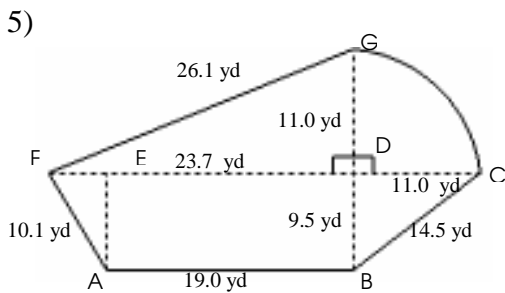
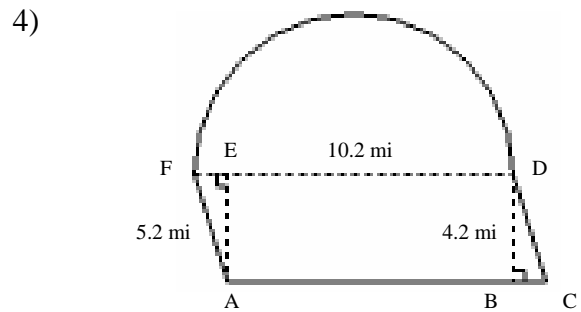
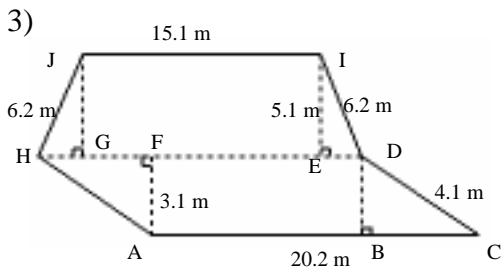
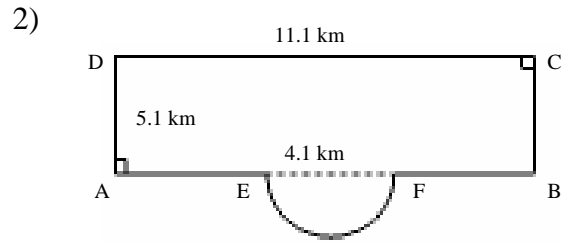
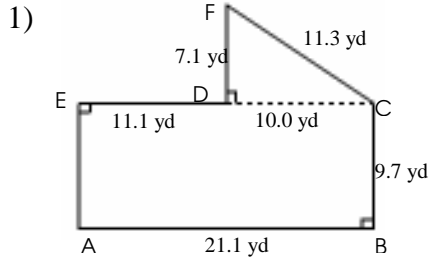

# Area and Perimeter of Compound Shapes Answer (F)

Instructions: Find the area and perimeter of each compound shape.

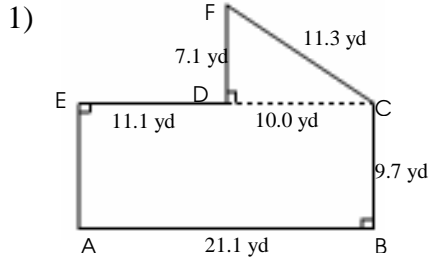

Area = Area of ABCE + Area of CDF  
 $= (AB \times BC) + (0.5 \times CD \times FD)$   
 $= (21.1 \times 9.7) + (0.5 \times 10.0 \times 7.1)$   
 $= 240.2 \text{ yd}^2$

Perimeter =  $(2 \times BC) + AB + CF + FD + DE$   
 $= (2 \times 9.7) + 21.1 + 11.3 + 7.1 + 11.1$   
 $= 70 \text{ yd}$

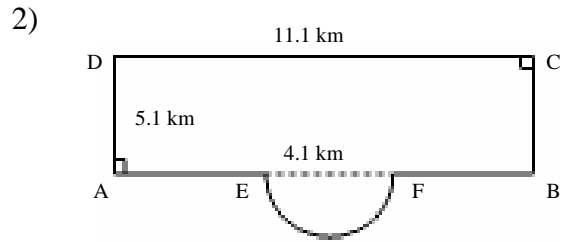

Area = Area of ABCD + Area of Part Circle EF  
 $= (AD \times DC) + 0.5 \Pi (0.5 EF)^2$   
 $= (5.1 \times 11.1) + 0.5 \times 3.14 \times (0.5 \times 4.1)^2$   
 $= 63.2 \text{ km}^2$

Perimeter =  $2 \times (AD + CD) + \text{Arc EF}$   
 $= 2 \times (5.1 + 11.1) + 0.5 \times 3.14 \times 4.1$   
 $= 34.7 \text{ km}$

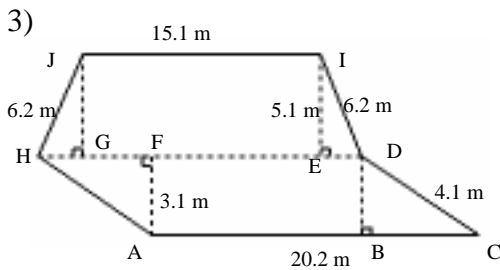

Area = Area of ACDH + Area of HDIJ  
 $= (AF \times AC) + 0.5 \times (HD + IJ) \times EI$   
 $= (3.1 \times 20.2) + 0.5 \times (20.2 + 15.1) \times 5.1$   
 $= 152.6 \text{ m}^2$

Perimeter =  $(2 \times AH) + (2 \times JH) + JI + AC$   
 $= (2 \times 4.1) + (2 \times 6.2) + 15.1 + 20.2$   
 $= 55.9 \text{ m}$

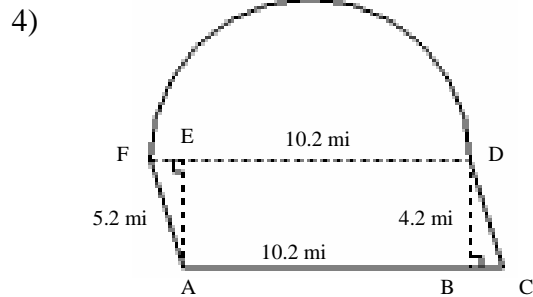

Area = Area of ACDF + Area of Part Circle FD  
 $= (BD \times DF) + 0.5 \Pi (0.5 DF)^2$   
 $= (4.2 \times 10.2) + 0.5 \times 3.14 \times (0.5 \times 10.2)^2$   
 $= 83.7 \text{ mi}^2$

Perimeter =  $(2 \times AF) + DF + \text{Arc DF}$   
 $= (2 \times 5.2) + 10.2 + 0.5 \times 3.14 \times 10.2$   
 $= 36.6 \text{ mi}$

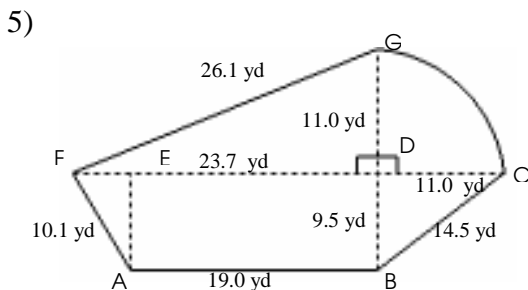

Area = Area of (ABCF + DFG) + Area of Part Circle GDC  
 $= (0.5 \times (AB + FD + DC) \times BD) + (0.5 \times FD \times DG) + 0.25 \Pi (DG)^2$   
 $= (0.5 \times (23.7 + 19.0 + 11.0) \times 9.5) + (0.5 \times 23.7 \times 11.0) + 0.25 \Pi (11.0)^2$   
 $= 480.4 \text{ yd}^2$

Perimeter =  $AB + BC + \text{Arc CG} + GF + FA$   
 $= 19.1 + 14.2 + 0.25 \times 3.14 \times 2 \times 11.0 + 26.1 + 10.1$   
 $= 86.7 \text{ yd}$

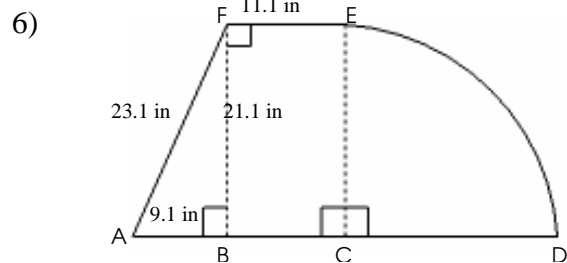

Area = Area of ABF + Area of BCEF + Area of Part Circle DCE  
 $= (0.5 \times AB \times BF) + (BC \times BF) + 0.25 \Pi (BC)^2$   
 $= (0.5 \times 9.1 \times 21.1) + (11.1 \times 21.1) + 0.25 \times 3.14 (21.1)^2$   
 $= 679.7 \text{ in}^2$

Perimeter =  $AB + (2 \times BC) + \text{Arc DE} + AF$   
 $= 9.1 + (2 \times 11.1) + 0.25 \times 3.14 \times 2 \times 21.1 + 23.1$   
 $= 87.5 \text{ in}$

## Area and Perimeter of Compound Shapes (G)

Instructions: Find the area and perimeter of each compound shape.

1)

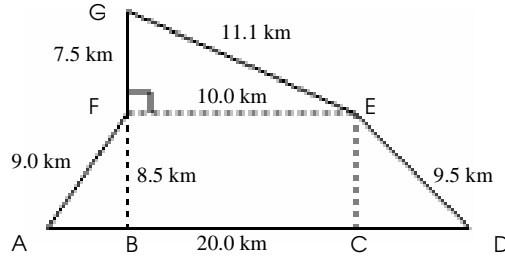

2)

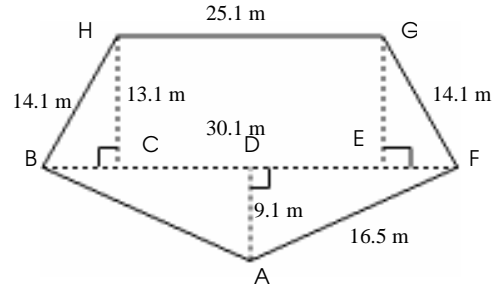

3)

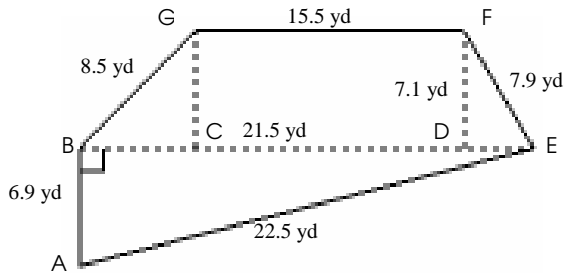

4)

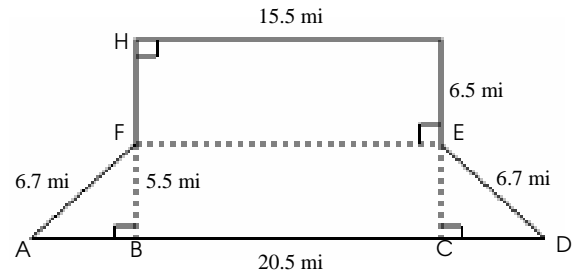

5)

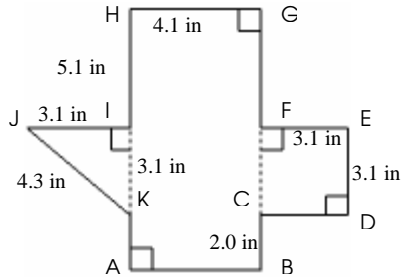

6)

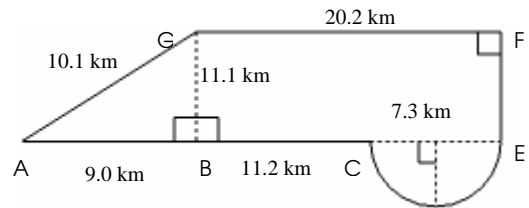

# Area and Perimeter of Compound Shapes Answer (G)

Instructions: Find the area and perimeter of each compound shape.

1)

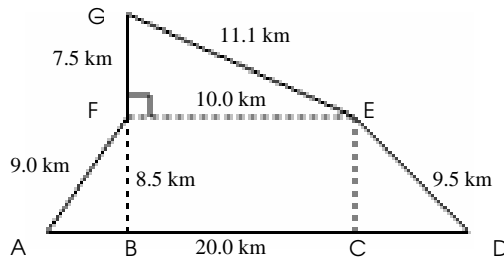

Area = Area of ADEF + Area of EFG  
 $= (0.5 \times (AD + EF) \times BF) + (0.5 \times EF \times FG)$   
 $= (0.5 \times (20.0 + 10.0) \times 8.5) + (0.5 \times 10.0 \times 7.5)$   
 $= 165.0 \text{ km}^2$

Perimeter =  $AD + DE + EG + GF + FA$   
 $= 20.0 + 9.5 + 11.1 + 7.5 + 9.0$   
 $= 57.1 \text{ km}$

2)

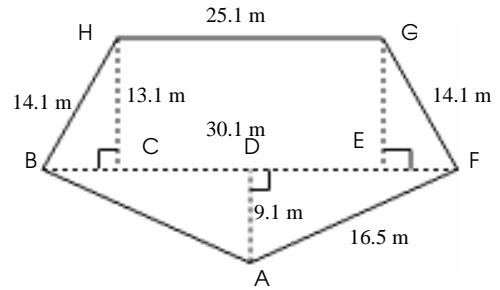

Area = Area of ABF + Area of BFGH  
 $= (0.5 \times AD \times BF) + (0.5 \times (BF + GH) \times CH)$   
 $= (0.5 \times 9.1 \times 30.1) + (0.5 \times (30.1 + 25.1) \times 13.1)$   
 $= 498.5 \text{ m}^2$

Perimeter =  $(2 \times AF) + GH + (2 \times FG)$   
 $= (2 \times 16.5) + 25.1 + (2 \times 14.1)$   
 $= 86.3 \text{ m}$

3)

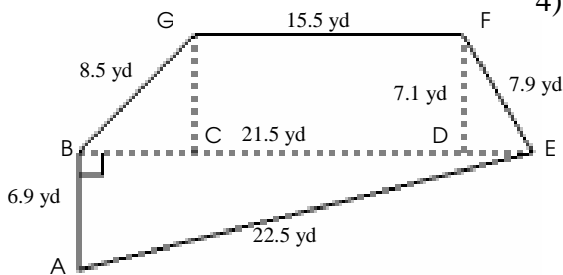

Area = Area of ABE + Area of BEFG  
 $= (0.5 \times AB \times BE) + (0.5 \times (BE + GF) \times DF)$   
 $= (0.5 \times 6.9 \times 21.5) + (0.5 \times (21.5 + 15.5) \times 7.1)$   
 $= 205.5 \text{ yd}^2$

Perimeter =  $BA + AE + EF + FG + GB$   
 $= 6.9 + 22.5 + 7.9 + 15.5 + 8.5$   
 $= 61.3 \text{ yd}$

4)

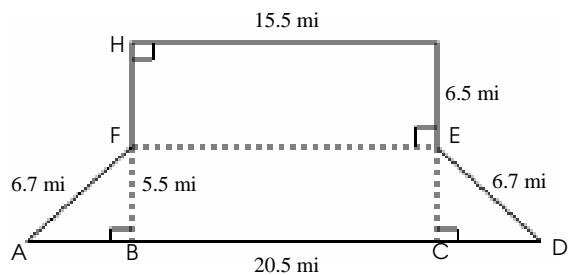

Area = Area of ADEF + Area of EFGH  
 $= (0.5 \times (AD + FE) \times BF) + (EG \times GH)$   
 $= (0.5 \times (20.5 + 15.5) \times 5.5) + (6.5 \times 15.5)$   
 $= 199.8 \text{ mi}^2$

Perimeter =  $(2 \times AF) + AD + (2 \times EG) + GH$   
 $= (2 \times 6.7) + 20.5 + (2 \times 6.5) + 15.5$   
 $= 62.4 \text{ mi}$

5)

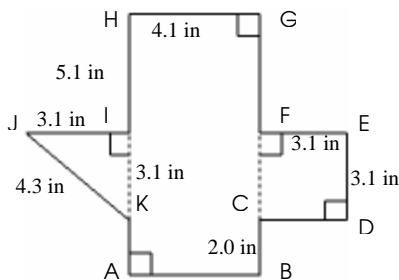

Area = Area of IJK + Area of ABGH + Area of CDEF  
 $= (0.5 \times IK \times JK) + ((GF + ED + BC) \times AB) + (FE)^2$   
 $= (0.5 \times 3.1 \times 3.1) + ((5.1 + 3.1 + 2.0) \times 4.1) + (3.1)^2$   
 $= 56.2 \text{ in}^2$

Perimeter =  $(2 \times AB) + (2 \times BC) + (3 \times FE) + (2 \times GF) + IJ + JK$   
 $= (2 \times 4.1) + (2 \times 2.0) + (3 \times 3.1) + (2 \times 5.1) + 3.1 + 4.3$   
 $= 39.1 \text{ in}$

6)

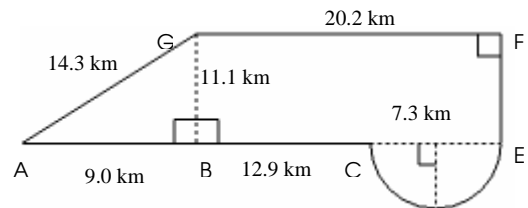

Area = Area of ABG + Area of BEFG + Area of Part Circle CE  
 $= (0.5 \times AB \times BG) + (BG \times FG) + 0.5 \Pi (0.5 CE)^2$   
 $= (0.5 \times 9.0 \times 11.1) + (11.1 \times 20.2) + 0.5 \Pi (0.5 \times 7.3)^2$   
 $= 295.1 \text{ km}^2$

Perimeter =  $AB + BC + \text{Arc CE} + FE + FG + GA$   
 $= 9.0 + 12.9 + 0.5 \times 3.14 \times 7.3 + 11.1 + 20.2 + 14.3$   
 $= 79.0 \text{ km}$

## Area and Perimeter of Compound Shapes (H)

Instructions: Find the area and perimeter of each compound shape.

1)

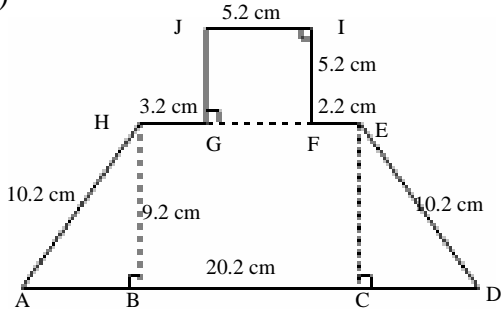

2)

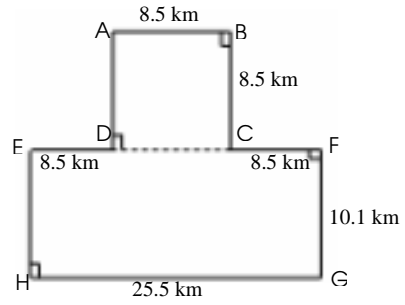

3)

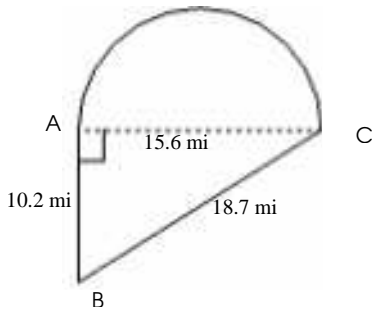

4)

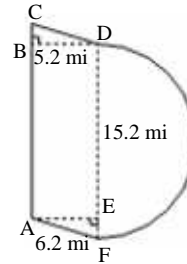

5)

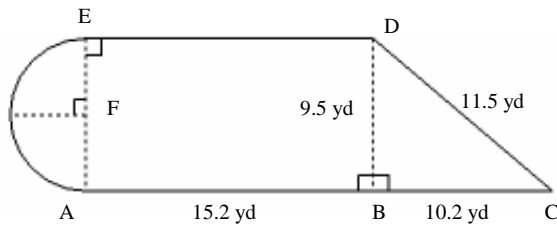

6)

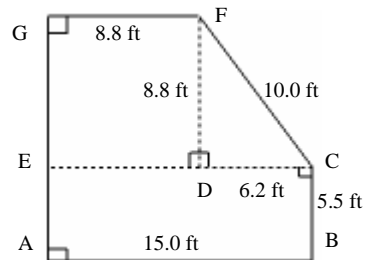

# Area and Perimeter of Compound Shapes Answer (H)

Instructions: Find the area and perimeter of each compound shape.

1)

Area = Area of ADEH + Area of GFJI  
 $= (0.5 \times (AD + HG + JI + FE) \times BH) + (JI)^2$   
 $= (0.5 \times (20.2 + 3.2 + 5.2 + 2.2) \times 9.2) + (5.2)^2$   
 $= 168.7 \text{ cm}^2$

Perimeter =  $AD + (2 \times AH) + EF + (3 \times JI) + GH$   
 $= 20.2 + (2 \times 10.2) + 2.2 + (3 \times 5.2) + 3.2$   
 $= 61.6 \text{ cm}$

2)

Area = Area of ABCD + Area of EFGH  
 $= (AB \times BC) + (HG \times FG)$   
 $= (25.5 \times 10.1) + (8.5 \times 8.5)$   
 $= 329.8 \text{ km}^2$

Perimeter =  $(5 \times AB) + (2 \times FG) + GH$   
 $= (5 \times 8.5) + (2 \times 10.1) + 25.5$   
 $= 88.2 \text{ km}$

3)

Area = Area of ABC + Area of Part Circle AC  
 $= (0.5 \times AB \times AC) + 0.5 \Pi (0.5 AC)^2$   
 $= (0.5 \times 10.2 \times 15.6) + 0.5 \times 3.14 (0.5 \times 15.6)^2$   
 $= 175.1 \text{ mi}^2$

Perimeter =  $AB + BC + \text{Arc AC}$   
 $= 10.2 + 18.7 + 0.5 \times 3.14 \times 15.6$   
 $= 53.4 \text{ mi}$

4)

Area = Area of ACDF + Area of Part Circle DF  
 $= (BD \times DF) + 0.5 \Pi (0.5 DF)^2$   
 $= (5.2 \times 15.2) + 0.5 \times 3.14 \times (0.5 \times 15.2)^2$   
 $= 169.7 \text{ mi}^2$

Perimeter =  $(2 \times AF) + CA + \text{Arc DF}$   
 $= (2 \times 6.2) + 15.2 + 0.5 \times 3.14 \times 15.2$   
 $= 51.5 \text{ mi}$

5)

Area = Area of (ABDE + BCD) + Area of Part Circle AFE  
 $= (AB \times BD) + (0.5 \times BC \times BD) + 0.5 \Pi (0.5 AE)^2$   
 $= (15.2 \times 9.5) + (0.5 \times 10.2 \times 9.5) + 0.5 \Pi (0.5 \times 9.5)^2$   
 $= 228.3 \text{ yd}^2$

Perimeter =  $(2 \times AB) + \text{Arc AE} + BC + CD$   
 $= (2 \times 15.2) + 0.5 \times 3.14 \times 9.5 + 10.2 + 11.5$   
 $= 67.0 \text{ yd}$

6)

Area = Area of ABCE + Area of CDF + Area of EDFG  
 $= (AB \times BC) + (0.5 \times CD \times DF) + (GF)^2$   
 $= (15.0 \times 5.5) + (0.5 \times 6.2 \times 8.8) + (8.8)^2$   
 $= 187.2 \text{ ft}^2$

Perimeter =  $(2 \times BC) + CF + (2 \times FG) + AB$   
 $= (2 \times 5.5) + 10.0 + (2 \times 8.8) + 15.0$   
 $= 53.6 \text{ ft}$

## Area and Perimeter of Compound Shapes (I)

Instructions: Find the area and perimeter of each compound shape.

1)

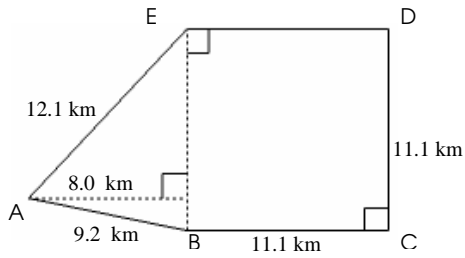

2)

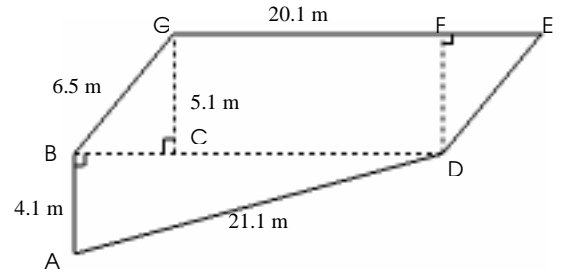

3)

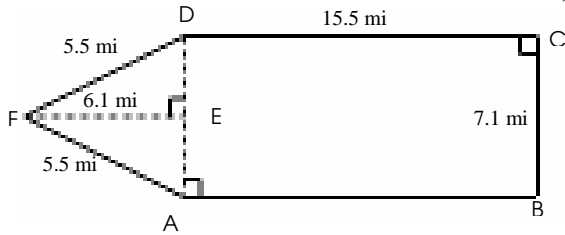

4)

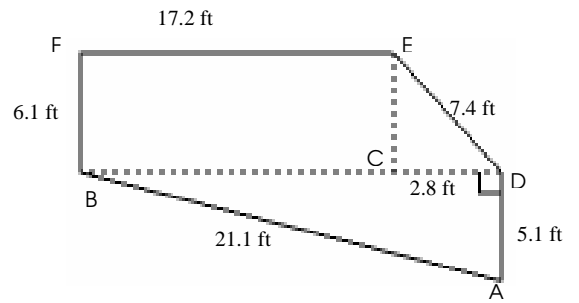

5)

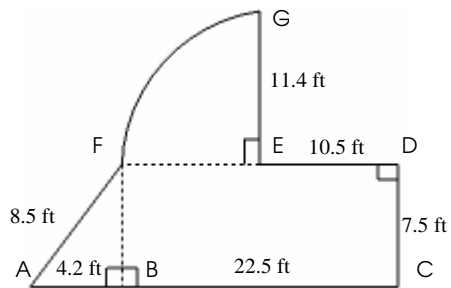

6)

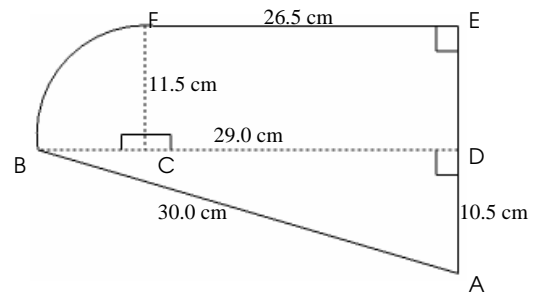

# Area and Perimeter of Compound Shapes Answer (I)

Instructions: Find the area and perimeter of each compound shape.

1)

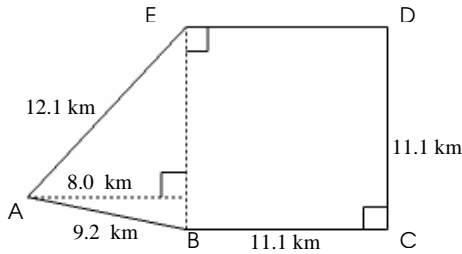

Area = Area of ABE + Area of BCDE  
 $= (0.5 \times AB \times BE) + (CD)^2$   
 $= (0.5 \times 8.0 \times 11.1) + (11.1)^2$   
 $= 167.6 \text{ km}^2$

Perimeter =  $AB + (3 \times CD) + AE$   
 $= 9.2 + (3 \times 11.1) + 12.1$   
 $= 54.6 \text{ km}$

2)

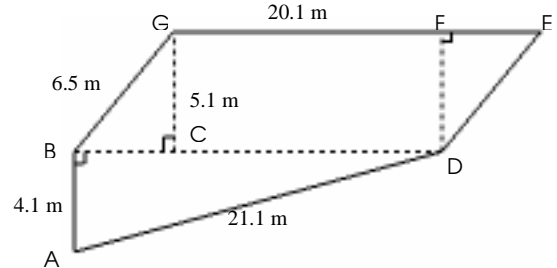

Area = Area of ABD + Area of BDEG  
 $= (0.5 \times AD \times AB) + (CG \times EG)$   
 $= (0.5 \times 20.1 \times 4.1) + (5.1 \times 20.1)$   
 $= 143.7 \text{ m}^2$

Perimeter =  $AB + AD + (2 \times BG) + EG$   
 $= 4.1 + 21.1 + (2 \times 6.5) + 20.1$   
 $= 58.3 \text{ m}$

3)

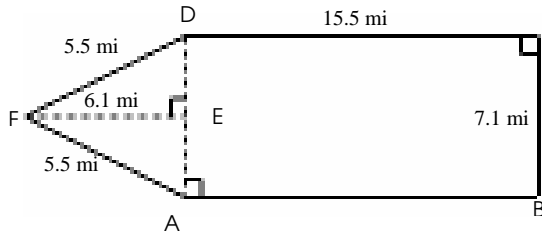

Area = Area of ABCD + Area of ADF  
 $= (BC \times CD) + (0.5 \times BC \times FE)$   
 $= (7.1 \times 15.5) + (0.5 \times 7.1 \times 6.1)$   
 $= 131.7 \text{ mi}^2$

Perimeter =  $(2 \times AB) + BC + (2 \times AF)$   
 $= (2 \times 15.5) + 7.1 + (2 \times 5.5)$   
 $= 49.1 \text{ mi}$

4)

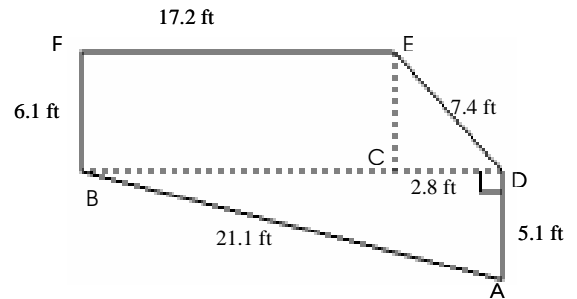

Area = Area of ABD + Area of BDEF  
 $= (0.5 \times AD \times AB) + (0.5 \times (BD + EF) \times CE)$   
 $= (0.5 \times 5.1 \times 21.1) + (0.5 \times (20.0 + 17.2) \times 6.1)$   
 $= 167.3 \text{ ft}^2$

Perimeter =  $AB + AD + ED + EF + FB$   
 $= 21.1 + 5.1 + 7.4 + 17.2 + 6.1$   
 $= 56.9 \text{ ft}$

5)

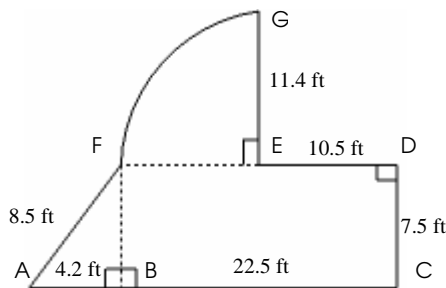

Area = Area of (ABF + BCDF) + Area of Part Circle EFG  
 $= (0.5 \times AB \times BF) + (BC \times CD) + 0.25 \Pi (FE)^2$   
 $= (0.5 \times 4.2 \times 8.5) + (22.5 \times 7.5) + 0.25 \times 3.14 \times (11.4)^2$   
 $= 286.5 \text{ ft}^2$

Perimeter =  $AB + BC + CD + DE + \text{Arc FG} + FA + EG$   
 $= 4.2 + 22.5 + 7.5 + 10.5 + (0.25 \times 3.14 \times 2 \times 11.4) + 8.5 + 11.4$   
 $= 82.5 \text{ ft}$

6)

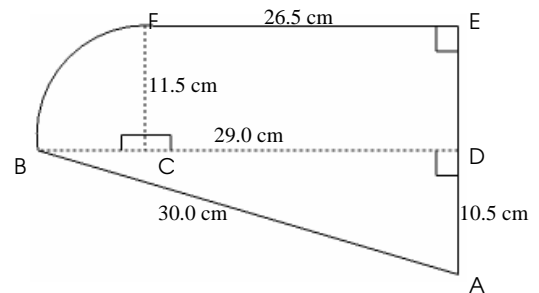

Area = Area of ABD + CDEF + Area of Part Circle BCF  
 $= (0.5 \times AD \times BD) + (EF \times CF) + 0.25 \Pi (EC)^2$   
 $= (0.5 \times 10.5 \times 29.0) + (26.5 \times 11.5) + 0.25 \times 3.14 \times (11.5)^2$   
 $= 560.8 \text{ cm}^2$

Perimeter =  $BA + AD + ED + EF + \text{Arc BF}$   
 $= 30.0 + 10.5 + 11.5 + 26.5 + (0.25 \times 3.14 \times 2 \times 11.5)$   
 $= 96.6 \text{ cm}$

## Area and Perimeter of Compound Shapes (J)

Instructions: Find the area and perimeter of each compound shape.

1)

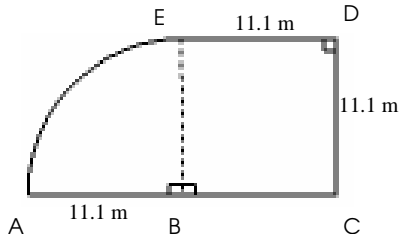

2)

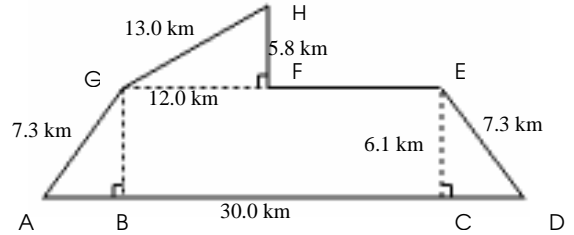

3)

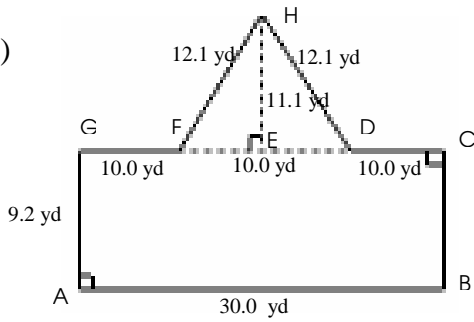

4)

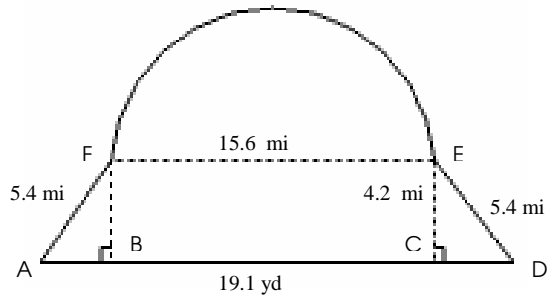

5)

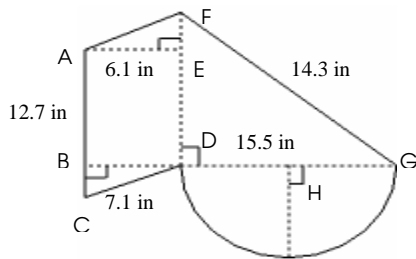

6)

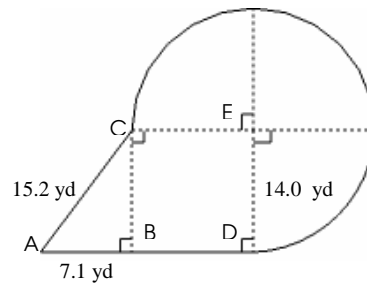

# Area and Perimeter of Compound Shapes Answer (J)

Instructions: Find the area and perimeter of each compound shape.

1)

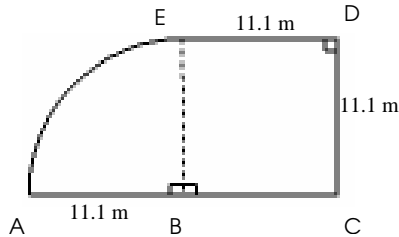

Area = Area of BCDE + Area of Part Circle ABE  
 $= (DC)^2 + 0.25 \Pi (EB)^2$   
 $= (11.1)^2 + 0.25 \times 3.14 \times (11.1)^2$   
 $= 219.9 \text{ m}^2$

Perimeter =  $(4 \times CD) + \text{Arc AE}$   
 $= (4 \times 11.1) + (0.25 \times 3.14 \times 2 \times 11.1)$   
 $= 61.8 \text{ m}$

2)

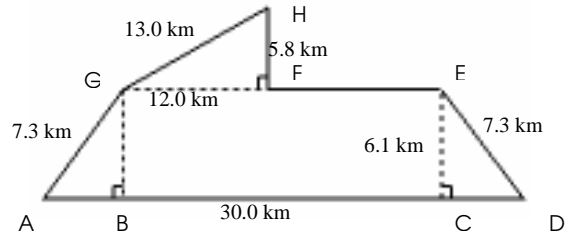

Area = Area of ADEG + Area of FGH  
 $= (0.5 \times (AD + EF + FG) \times CE) + (0.5 \times FH \times FG)$   
 $= (0.5 \times (30.0 + 13.0 + 12.0) \times 6.1) + (0.5 \times 5.8 \times 12.0)$   
 $= 202.6 \text{ km}^2$

Perimeter =  $(2 \times AG) + AD + EF + FH + HG$   
 $= (2 \times 7.3) + 30.0 + 13.0 + 5.8 + 13.0$   
 $= 76.4 \text{ km}$

3)

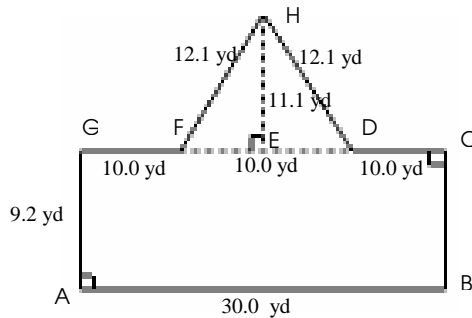

Area = Area of ABCG + Area of FDH  
 $= (AD \times AG) + (0.5 \times DF \times EH)$   
 $= (30.0 \times 9.2) + (0.5 \times 10.0 \times 11.1)$   
 $= 331.5 \text{ yd}^2$

Perimeter =  $(2 \times AG) + AB + (2 \times FH) + (2 \times CD)$   
 $= (2 \times 9.2) + 30.0 + (2 \times 12.1) + (2 \times 10.0)$   
 $= 92.6 \text{ yd}$

4)

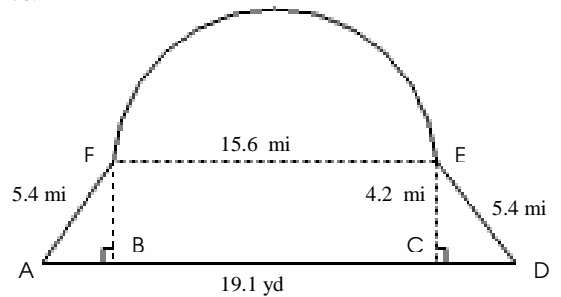

Area = Area of ADEF + Area of Part Circle FE  
 $= (0.5 \times (AD + FE) \times CE) + 0.5 \Pi (0.5 FE)^2$   
 $= (0.5 \times (19.1 + 15.6) \times 4.2) + 0.5 \times 3.14 \times (0.5 \times 15.6)^2$   
 $= 168.4 \text{ mi}^2$

Perimeter =  $(2 \times AF) + AD + \text{Arc FE}$   
 $= 11.1 + 19.1 + (0.5 \times 3.14 \times 15.6)$   
 $= 54.4 \text{ mi}$

5)

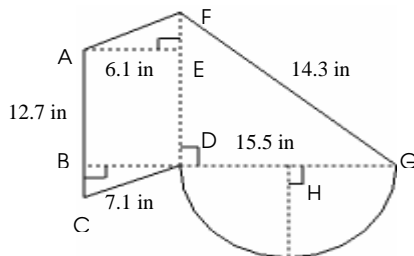

Area = Area of (ACDF + DFG) + Area of Part Circle DHG  
 $= (AC \times AE) + (0.5 \times DG \times DF) + 0.5 \Pi (0.5 DG)^2$   
 $= (12.7 \times 6.1) + (0.5 \times 15.5 \times 12.7) + 0.5 \times 3.14 \times (0.5 \times 15.5)^2$   
 $= 270.2 \text{ in}^2$

Perimeter = Arc DG + FG +  $(2 \times AF) + AC$   
 $= (0.5 \times 3.14 \times 15.5) + 14.3 + (2 \times 7.1) + 12.7$   
 $= 65.5 \text{ ft}$

6)

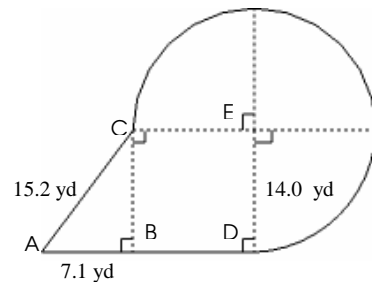

Area = Area of (ABD + BCDE) + Area of Part Circle CDE  
 $= (0.5 \times AB \times BC) + (ED)^2 + 0.75 \Pi (ED)^2$   
 $= (0.5 \times 7.1 \times 14.0) + (14.0)^2 + 0.75 \times 3.14 \times (14.0)^2$   
 $= 707.3 \text{ yd}^2$

Perimeter = AB + BD + Arc DE + CA  
 $= 7.1 + 14.0 + (0.75 \times 3.14 \times 2 \times 14.0) + 15.2$   
 $= 102.2 \text{ yd}$