

Volume and Surface Area of Right Prisms (J)

Instructions: Find the volume and surface area for each right prism.

1)

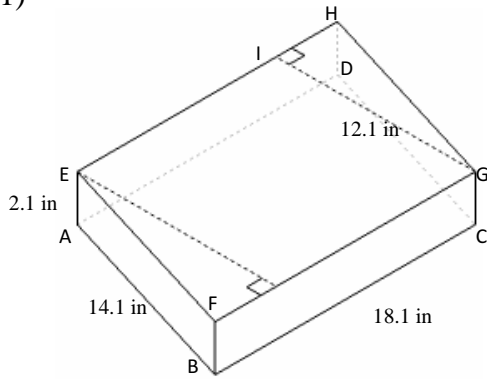

2)

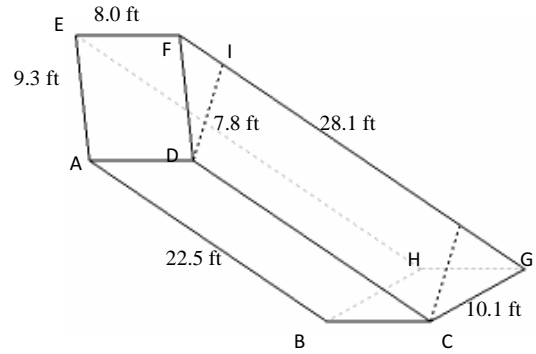

3)

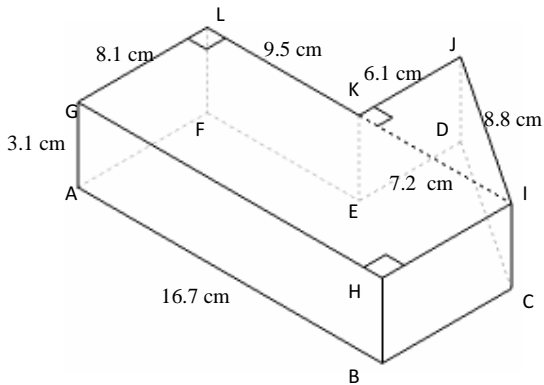

4)

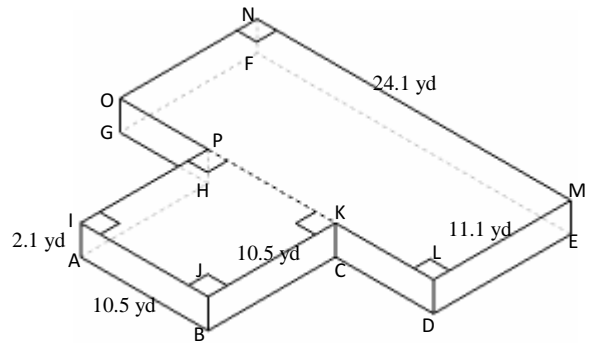

Volume and Surface Area of Right Prisms Answer (J)

Instructions: Find the volume and surface area for each right prism.

1)

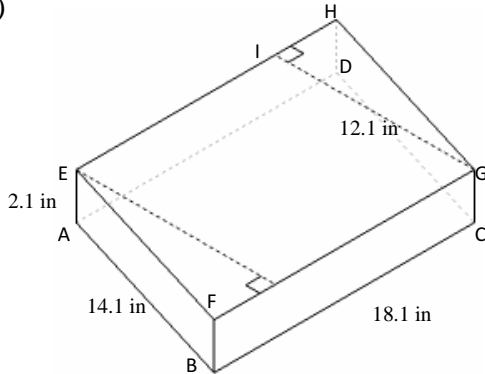

$$\begin{aligned} V &= \text{Area of } ABCD \times AE \\ &= (BC \times GI) \times AE \\ &= (18.1 \times 12.1) \times 2.1 \\ &= 459.9 \text{ in}^3 \end{aligned}$$

$$\begin{aligned} A &= (2 \times \text{Area of } ABCD) + (\text{perimeter of } ABCD \times AE) \\ &= (2 \times (BC \times GI)) + ((2 \times AB) + (2 \times BC)) \times AE \\ &= (2 \times (18.1 \times 12.1)) + (((2 \times 14.1) + (2 \times 18.1)) \times 2.1) \\ &= 573.3 \text{ in}^2 \end{aligned}$$

2)

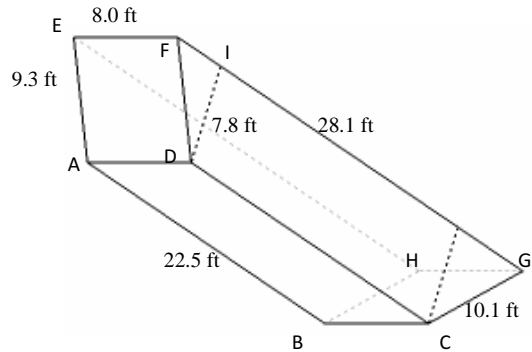

$$\begin{aligned} V &= \text{Area of } CDFG \times EF \\ &= (0.5 \times (CD + FG) \times DI) \times EF \\ &= (0.5 \times (22.5 + 28.1) \times 7.8) \times 8.0 \\ &= 1578.7 \text{ ft}^3 \end{aligned}$$

$$\begin{aligned} A &= (2 \times \text{Area of } CDFG) + (\text{perimeter of } CDFG \times EF) \\ &= (2 \times (0.5 \times (CD + FG) \times DI)) + ((CD + DF + FG + GC) \times EF) \\ &= (2 \times (0.5 \times (22.5 + 28.1) \times 7.8)) + ((22.5 + 9.3 + 28.1 + 10.1) \times 8.0) \\ &= 954.7 \text{ ft}^2 \end{aligned}$$

3)

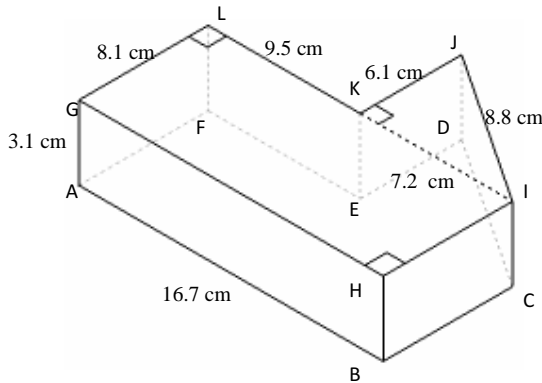

$$\begin{aligned} V &= (\text{Area of } GHIL + \text{Area of } IJK) \times AG \\ &= ((GH \times GL) + (0.5 \times KJ \times IK)) \times AG \\ &= ((16.7 \times 8.1) + (0.5 \times 6.1 \times 7.2)) \times 3.1 \\ &= 487.4 \text{ cm}^3 \end{aligned}$$

$$\begin{aligned} A &= (2 \times (\text{Area of } GHIL + \text{Area of } IJK)) + (\text{perimeter of } FGHIJ) \times AG \\ &= (2 \times ((GH \times GL) + (0.5 \times KJ \times IK))) + ((GH + 2 \times HI) + IJ + JK + KL) \times AG \\ &= (2 \times ((16.7 \times 8.1) + (0.5 \times 6.1 \times 7.2))) + ((16.7 + (2 \times 8.1)) + 8.8 + 6.1 + 9.5) \times 3.1 \\ &= 492.1 \text{ cm}^2 \end{aligned}$$

4)

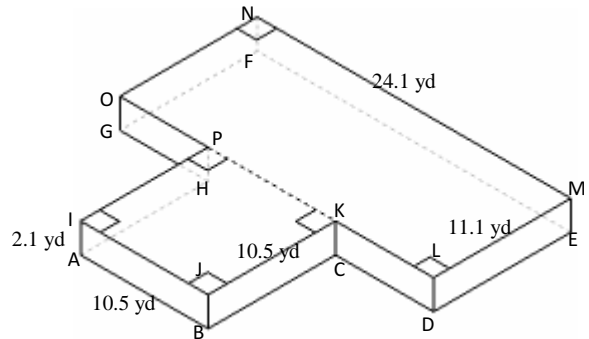

$$\begin{aligned} V &= (\text{Area of } ABCH + \text{Area of } DEFG) \times AI \\ &= ((AB)^2 + (EF \times ED)) \times AI \\ &= ((10.5)^2 + (24.1 \times 11.1)) \times 2.1 \\ &= 793.3 \text{ yd}^3 \end{aligned}$$

$$\begin{aligned} A &= (2 \times (\text{Area of } ABCH + \text{Area of } DEFG)) + (\text{perimeter of } ABCDEFGH) \times AI \\ &= (2 \times ((AB)^2 + (EF \times ED))) + (((2 \times AB) + (2 \times LM) + (2 \times MN)) \times AI) \\ &= (2 \times ((10.5)^2 + (24.1 \times 11.1))) + (((2 \times 10.5) + (2 \times 11.1) + (2 \times 24.1)) \times 2.1) \\ &= 947.5 \text{ yd}^2 \end{aligned}$$