

Surface Area and Volume of Conical Frustums (F)

Calculate the surface area and volume for each conical frustum.

$$\text{Surface Area} = \pi(r_1 + r_2)\sqrt{(r_1 - r_2)^2 + h^2} + \pi r_1^2 + \pi r_2^2 \quad \text{Volume} = \frac{\pi}{3}h(r_1^2 + r_2^2 + r_1 r_2)$$

1.

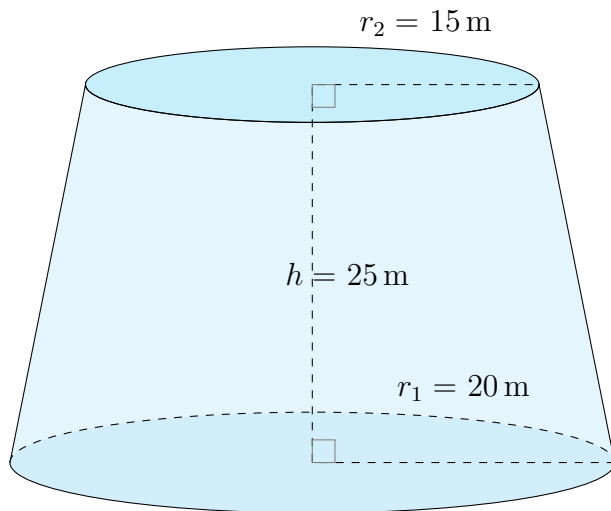

2.

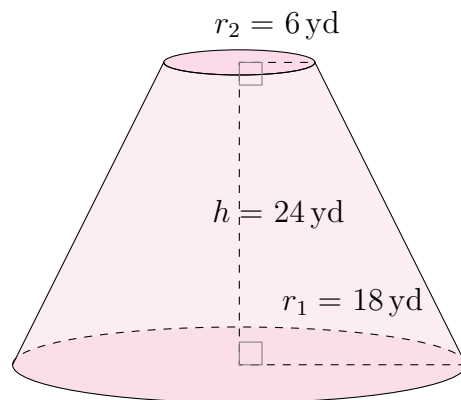

3.

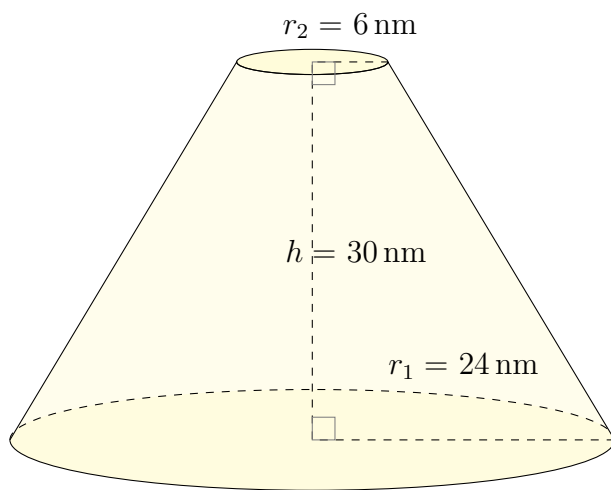

4.

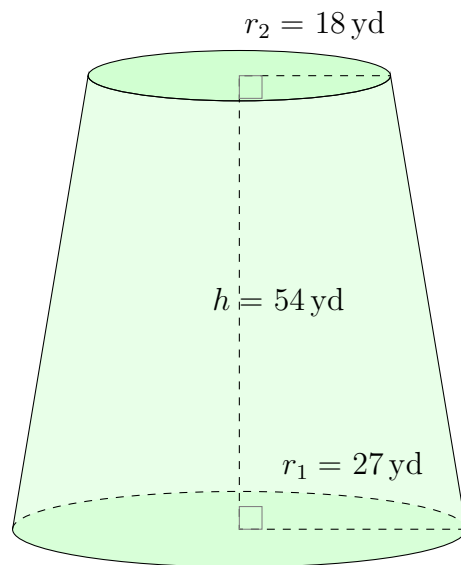

Surface Area and Volume of Conical Frustums (F) Answers

Calculate the surface area and volume for each conical frustum.

$$\text{Surface Area} = \pi(r_1 + r_2)\sqrt{(r_1 - r_2)^2 + h^2} + \pi r_1^2 + \pi r_2^2 \quad \text{Volume} = \frac{\pi}{3}h(r_1^2 + r_2^2 + r_1 r_2)$$

1.

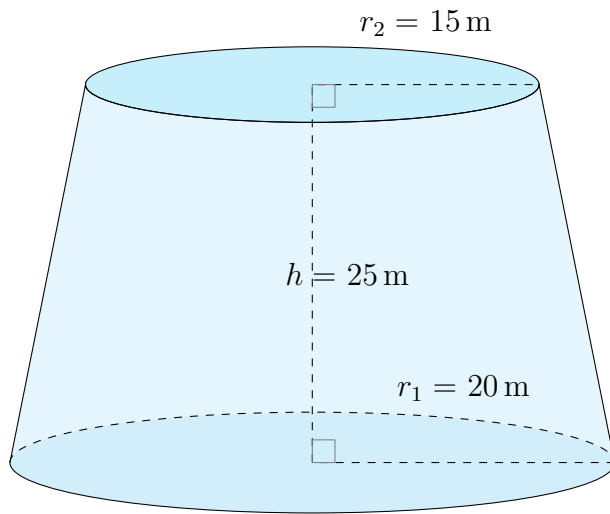

Surface Area: 4767 m^2
Volume: $24,216 \text{ m}^3$

2.

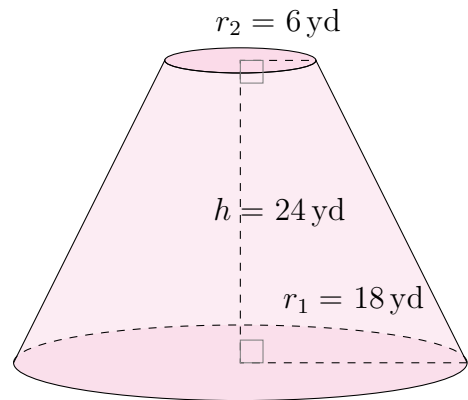

Surface Area: 3154 yd^2
Volume: $11,762 \text{ yd}^3$

3.

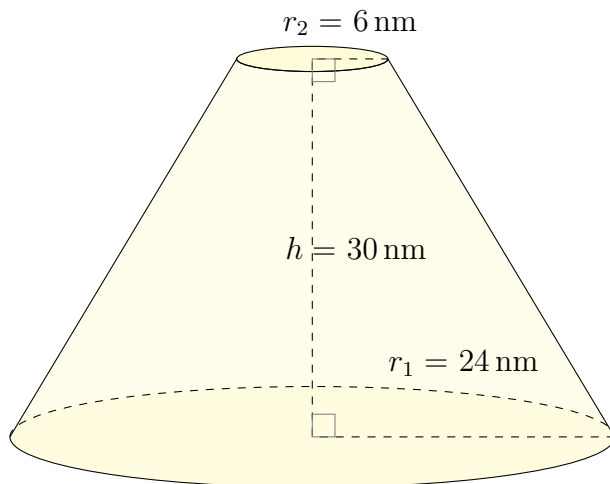

Surface Area: 5220 nm^2
Volume: $23,750 \text{ nm}^3$

4.

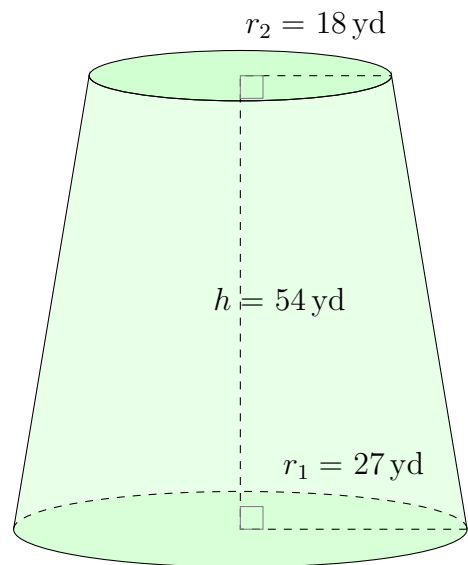

Surface Area: $11,047 \text{ yd}^2$
Volume: $87,028 \text{ yd}^3$